

SEIKO

Outdoor Clock Board

BT-501 *Clock Board*

OPERATING MANUAL

Thank you very much for purchasing this Seiko product.

Please read this user's manual carefully before operating the product to use it properly.

After reading, keep it in a safe place so that you can refer to it at any time.

セイコータイムクリエーション株式会社

SEIKO TIME CREATION INC.

Caution

- (1) The contents of this manual may not be copied or reproduced in any form, in whole or in part, without the express written consent of Seiko.
- (2) This manual may be subject to change without prior notice.
- (3) While the contents of this manual have been prepared with the utmost care, if you happen to discover any dubious points or errors, please contact us.
- (4) Please use this product properly according to the equipment and connection method described in this manual. Note that Seiko shall not be liable for any damages due to the customer's inappropriate use of the product or using it without properly following the contents of this user's manual, or due to repairs or modifications made by any third party other than Seiko or a servicing contractor designated by Seiko.

Symbols used within this manual

The meanings of the various symbols used within this manual are as follows.

 WARNING	Indicates a situation that could result in death or serious injury if handled incorrectly.
--	--

 CAUTION	Indicates a situation that may result in injury or property damage alone if handled incorrectly.
---	--

The following pictograms indicate actions that are prohibited.



General prohibitions



Do not disassemble



Do not use near water



Do not touch with wet hands



Do not get wet

The following pictograms indicate actions that are imperative.



General instructions













Unplug the power cable

Table of Contents

1. Safety Precautions	1
2. Overview.....	3
3. Features.....	3
4. Names and Functions of Each Part.....	3
5. Connection Method	5
6. Operation Method.....	6
7. Extended Connection	9
8. Operating Modes of the Control Panel.....	10
9. Cycle Mode.....	11
10. If a Communication Error Occurs	12
11. Configuration Details and Specifications	13

1. Safety Precautions

The following are precautions that must be observed in order for you to use the product safely and correctly and to prevent harm to you and others or damage to property.

 WARNING		
[Common to both control panel and display panel]		
Handling abnormalities	If you notice any abnormalities such as smoke or strange smells emanating from the product, immediately shut it off at the power source and stop using it. After confirming that smoke is no longer being emitted from the product, contact the dealer or distributor from whom you purchased the product to request repairs. Continuing to use the product without repair may result in electric shock or fire hazard.	
Cable connection precautions	Be sure to grip the power plug when unplugging the power cord from the outlet. Pulling on the cord may lead to electric shock, malfunction, or a fire hazard.	
Cable connection precautions	Do not use the product if the power cord or power plug is damaged or if the plug is loose in the power outlet. Doing so could create a risk of electric shock, short circuiting, or fire.	
No exposure to water droplets	The adapter with power cord (KT-ADP01) is a product for indoor use. Take care to protect it from exposure to water droplets when using it. Failure to do so may cause burnout or malfunction.	
Prohibition of disassembly, repair, and modification	Do not disassemble, repair, or modify this product unless you are a qualified repair technician. For repairs, contact the dealer or distributor from whom you purchased the product. Attempting these actions yourself may cause electric shock or fire.	
No infiltration of foreign objects	Do not insert foreign objects such as pins or metal objects inside the product. If any such objects or substances should get inside the product, immediately turn off the power switch. For inspection, contact Seiko or one of our agents. Continuing to use the product without resolving the problem may result in electric shock or fire hazard.	
No handling with wet hands	Do not operate the product or join connectors with wet hands. Doing so may cause electric shock or malfunction.	
Power connection precautions	Unplug the power plug from the outlet when not using the product. Leaving it plugged in may lead to electric shock, current leakage, or fire hazard due to insulation deterioration.	
[Control panel]		
No use near water	The control panel is not a drip-proof structure, so be sure to use it only in places where it will not be exposed to rain or water droplets. If rain or water droplets get on the control panel, it may cause a short circuit or electric shock.	

CAUTION

[Common to both control panel and display panel]

Do not leave the product in direct sunlight for a long period of time. Doing so may cause the internal temperature to rise and damage circuit components and other internal components.



Make sure that water droplets do not get on any of the connector parts. Exposure to water droplets may cause burnout or malfunction.



Avoid using the product in dusty locations. If dust gets inside the product or the connectors, there is a risk of short circuit or electric shock.



Make sure that solvents such as alcohol and gasoline, sprayed liquids such as cosmetics, cleaning agents, adhesives, paints, etc. do not adhere to the case or display surface. Chemical changes caused by such substances may lead to discoloration, deterioration, or damage.



[Control panel]

Be sure to turn off the power switch when connecting the power cord/cable. Also, do not use any power cord/cable other than the one specified. Failure to follow these precautions may lead to electric shock or malfunction.



[Display panel]

The display panel has a simple dust-proof and drip-proof structure, and is therefore not intended to be permanently installed outdoors. Set it up only when using it, store it in an appropriate place when not using it, and clean it regularly.



Do not set it up in a place where it could be hit directly by a ball. A direct hit from a ball could cause damage or malfunction.



2. Overview

The Seiko Clock Board is a display device that can accommodate various pitch clock rules of baseball: a 12-second timer for when bases are empty, a 20-second timer for when there are runners on bases, and a 30-second timer between batters.

3. Features

- Clear and easy-to-read characters with a height of 400 mm. (High brightness LEDs ideal for outdoor use.)
- The timer buttons have internal lights that indicate the operating status.
In addition, the control panel uses large switches that are shaped differently from other setting switches, making it very easy to use.
- The numerical values of each timer (12 sec, 20 sec, 30 sec, 99 sec) can be changed and the changed values can be saved in memory.
- The display panel can be expanded by combining it with optional additions.

4. Names and Functions of Each Part

Display panel

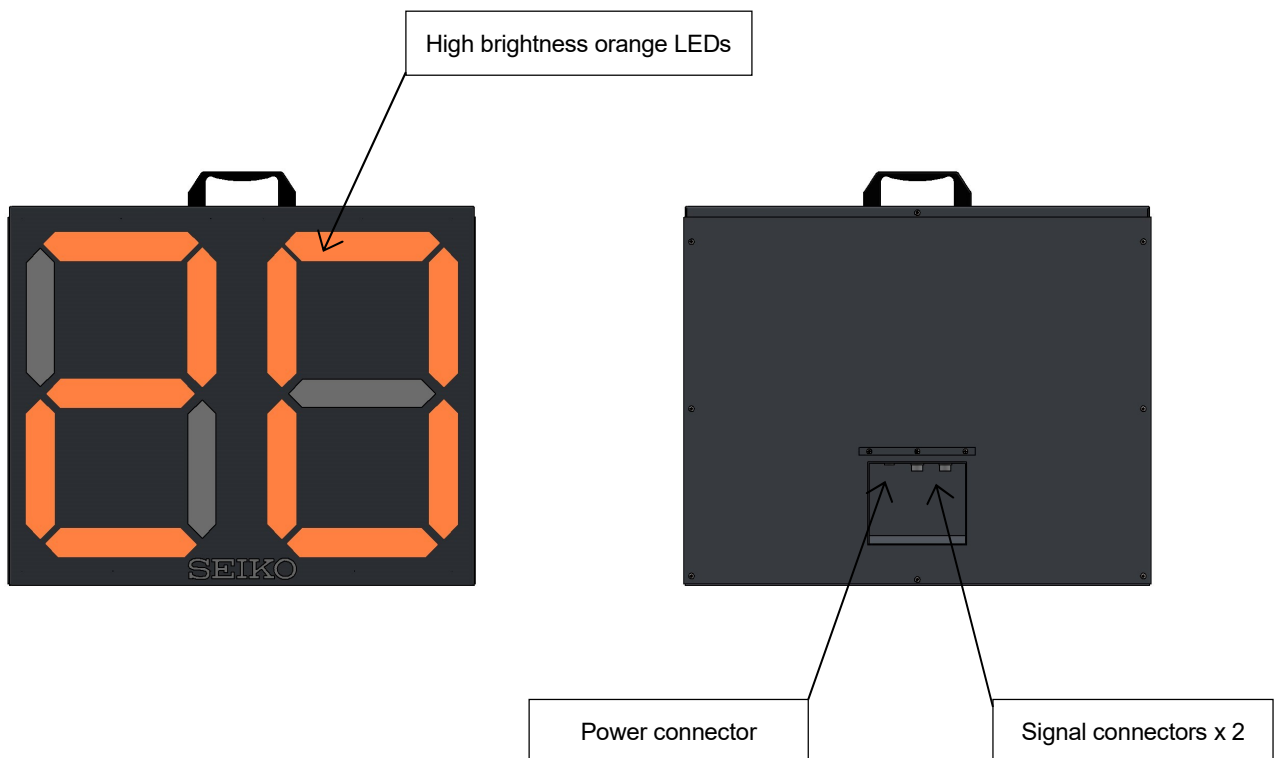

Control panel

<Top>

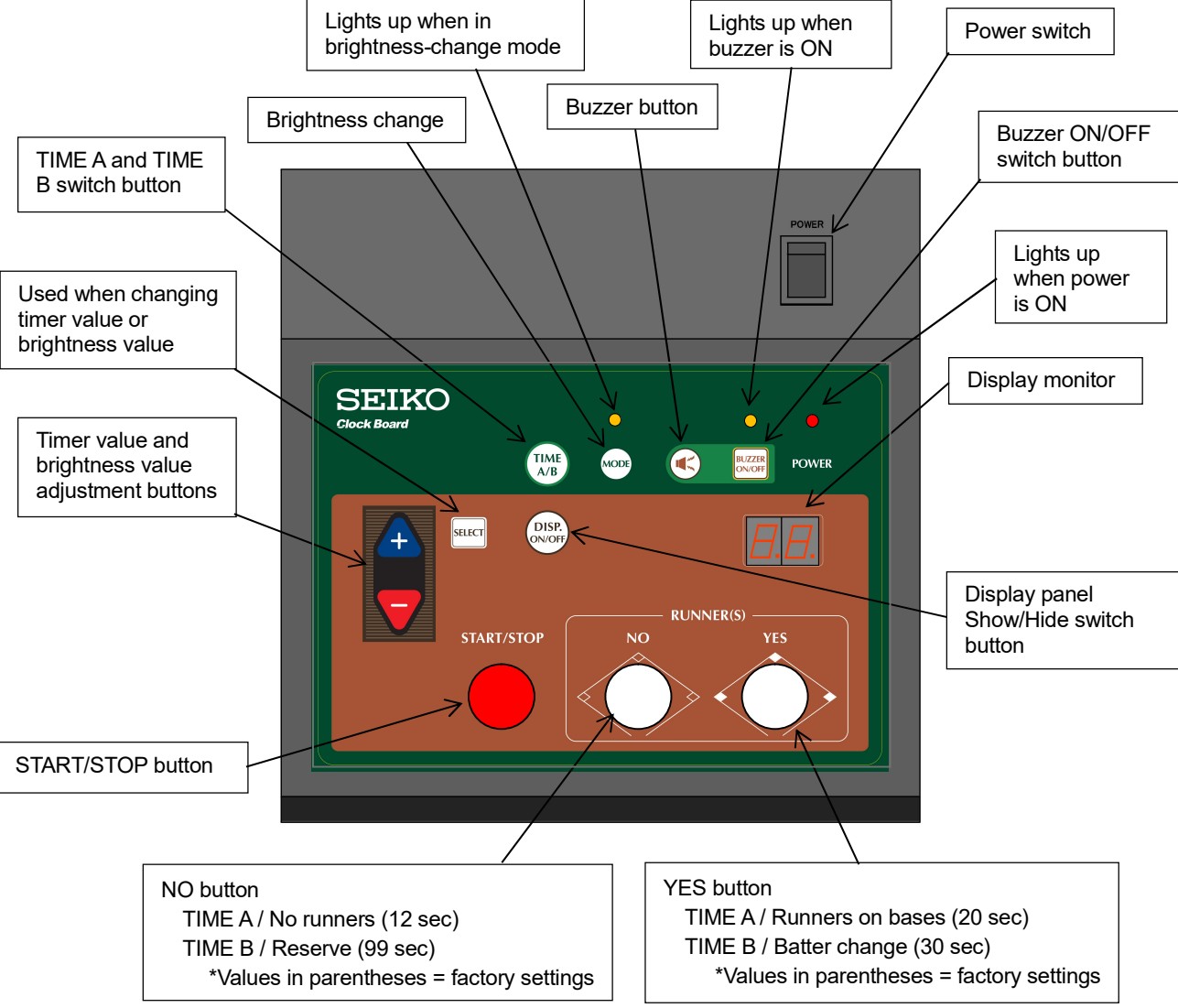

<Back>

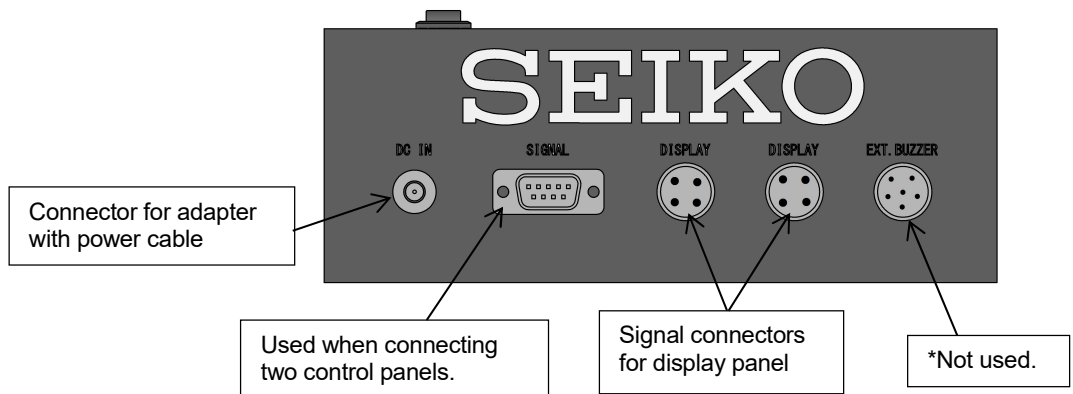

(Summary of functions of each button)



Use this button to select either buzzer ON or buzzer OFF for when the time is up. When the buzzer is ON, the LED is lit up.



When you press this button, the buzzer will sound for as long as you are pressing it.



With this button, you can switch to the LED brightness-change mode.



If you press this button to turn OFF the display, the buzzer will also turn OFF. The next time you turn the display back ON, the buzzer ON/OFF setting will return to the state it was in just before you turned the display OFF.



Press this button to switch between TIME A and TIME B.

TIME A : The default settings are 12 seconds for the NO button and 20 seconds for the YES button. (Can be changed.)

TIME B : The default settings are 99 seconds for the NO button and 30 seconds for the YES button. (Can be changed.)

For TIME B, a period [.] appears at the end of the display monitor. This [.] does not appear on the display panel.

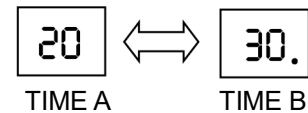

5. Connection Method

1. Securely insert the accompanying adapter with power cable into the power connector (DC IN) on the control panel, and then properly insert the power plug into the outlet.
2. Securely insert the signal cable into the signal connector on the back of the display panel and the signal connector on the back of the control panel, and tighten the nuts.

*The signal cable can be connected to either of the two connectors on the control panel and display panel.

<Standard connection configuration>

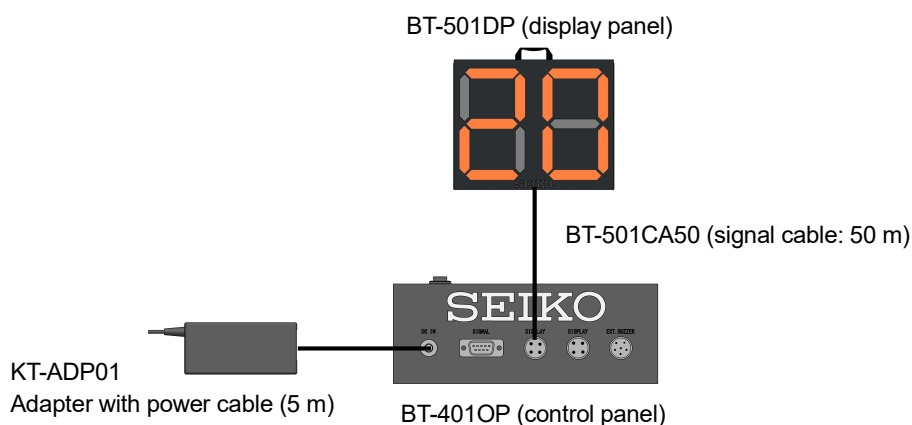









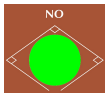





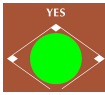





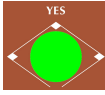









*For extended connections, refer to 7. Extended Connection.

6. Operation Method











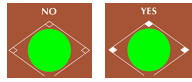

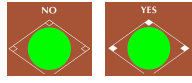

*Operation in normal mode (main unit)

●Operating procedures: Normal usage









	Operation details	Operation	Action	Display monitor
●When starting from 12 seconds (bases empty)				
1-1	Set timer to 12 seconds		Lights up green Timer is stopped	
1-2	Start measurement		Count starts *START/STOP button flashes red	 ⇒ 
1-3	End measurement		Automatically stops *If the buzzer is set to ON, the buzzer will sound.	 ⇒ 
●When starting from 20 seconds (runners on bases)				
2-1	Set timer to 20 seconds		Lights up green Timer is stopped	
2-2	Start measurement		Count starts *START/STOP button flashes red	 ⇒ 
2-3	End measurement		Automatically stops *If the buzzer is set to ON, the buzzer will sound.	 ⇒ 
●When starting from 30 seconds (batter change)				
3-1	Set timer to 20 seconds		Lights up green Timer is stopped	
3-2	Switch to TIME B		[.] appears at the end of the display monitor * [.] does not appear on the display panel.	 ⇒ 
3-3	Start measurement		Count starts *START/STOP button flashes red	 ⇒ 
3-4	End measurement		Automatically stops *If the buzzer is set to ON, the buzzer will sound.	 ⇒ 
●Stopping/correcting/restarting the timer while it is running				
4-1	Stop timer		Stops *START/STOP button lights up red	
4-2	Adjust timer		Example: When correcting 11 seconds to 10 seconds	 ⇒ 
4-3	Restart timer		Count starts *START/STOP button flashes red	 ⇒ 

• Changing measurement time settings

*Using the YES/NO button for TIME A/TIME B, you can change the settings of a total of 4 timers.

	Operation details	Operation	Action	Display monitor
• Select the time for which you want to change settings (TIME A or TIME B)				
1-1	Press YES or NO		Timer is reset.	Timer reset state Example:  
1-2	Select TIME A or TIME B		In the case of TIME B [.] appears at the end of the display monitor	Number of seconds of selected timer Example:  
• Select the button for which you want to change settings (YES or NO)				
2-1	Press the button for which you want to change the number of seconds		*START/STOP button lights up red *Selected button lights up green	Number of seconds of selected timer Example:  
2-2	Shift to the mode for changing the number of seconds		*START/STOP button lights up red *Selected button lights up green	Numbers on the monitor flash Example:  
2-3	Change the number of seconds using the [+] and [-] buttons		Example: Change selected button to 19 seconds	Number of seconds after change Example:  

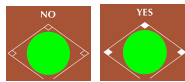



*If you want to change both YES and NO, repeat steps 2-1 to 2-3 and then proceed to "Confirmation of changes".

• Confirmation of changes				
<ul style="list-style-type: none"> • If you do not want to save the changed number of seconds to memory (changes remain valid until power is turned off) → Go to 3-1 • If you want to save the changed number of seconds to memory (changes are retained even when power is turned off) → Go to 4-1 				
3-1	Do not save changed number of seconds to memory		 Button flashes green 3 times	Numbers on the monitor light up Example:  
*If you want to cancel the change, turn off the power switch or press the  button for at least 2 seconds.				
4-1	Save changed number of seconds to memory		 Button flashes green 3 times	Numbers on the monitor light up Example:  













●Changing the LED brightness on the display panel

The brightness of the LEDs on the display panel can be set to any of 5 levels.

The brightness is set as a value from 1 to 5, with 5 being the maximum brightness. *The brightness is set to 5 at the time of factory shipment.

	Operation details	Operation	Action	Display monitor
●Shift to LED brightness-change mode				
1-1	Press MODE while the timer is stopped		Shifts to brightness-change mode *Display monitor flashes	Displays current brightness Example: 
●Change brightness				
1-2	Change brightness with the [+] and [-] buttons		Example: Changing brightness to 3	Brightness after change Example: 

*While checking the actual brightness on the display panel, select the appropriate brightness using the [+] and [-] buttons.

●Confirmation/cancellation of changes				
<ul style="list-style-type: none"> •If you do not want to save the changed brightness value to memory (changes remain valid until power is turned off) → Go to 2-1 •If you want to save the changed brightness value to memory (changes are retained even when power is turned off) → Go to 3-1 •To cancel the change and return to normal mode → Go to 4-1 				
2-1	Do not save changed brightness value to memory		 Button flashes green 3 times	Number display on the monitor returns to the timer  → 
3-1	Save changed brightness value to memory		  Button flashes green 3 times	Number display on the monitor returns to the timer  → 
4-1	Cancel change		Example: Changing brightness to 3	Number display on the monitor returns to the timer  → 

7. Extended Connection

The display panel can be expanded using optional additions.

1. When adding only an extra display panel

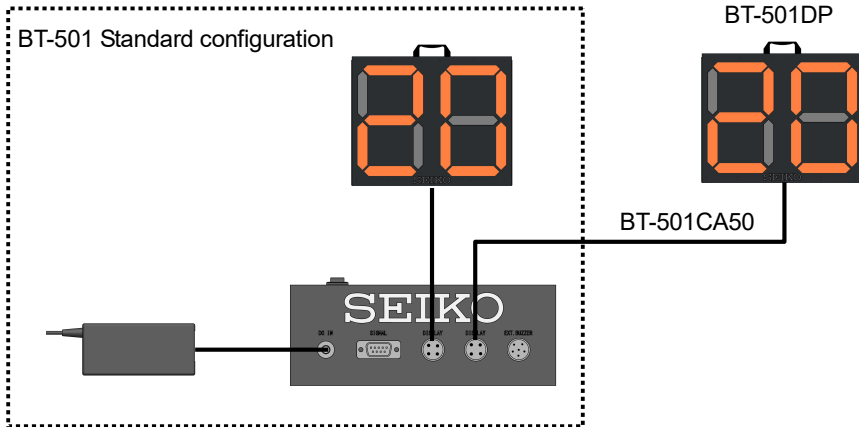

2. When adding extra display panels and an extra control panel

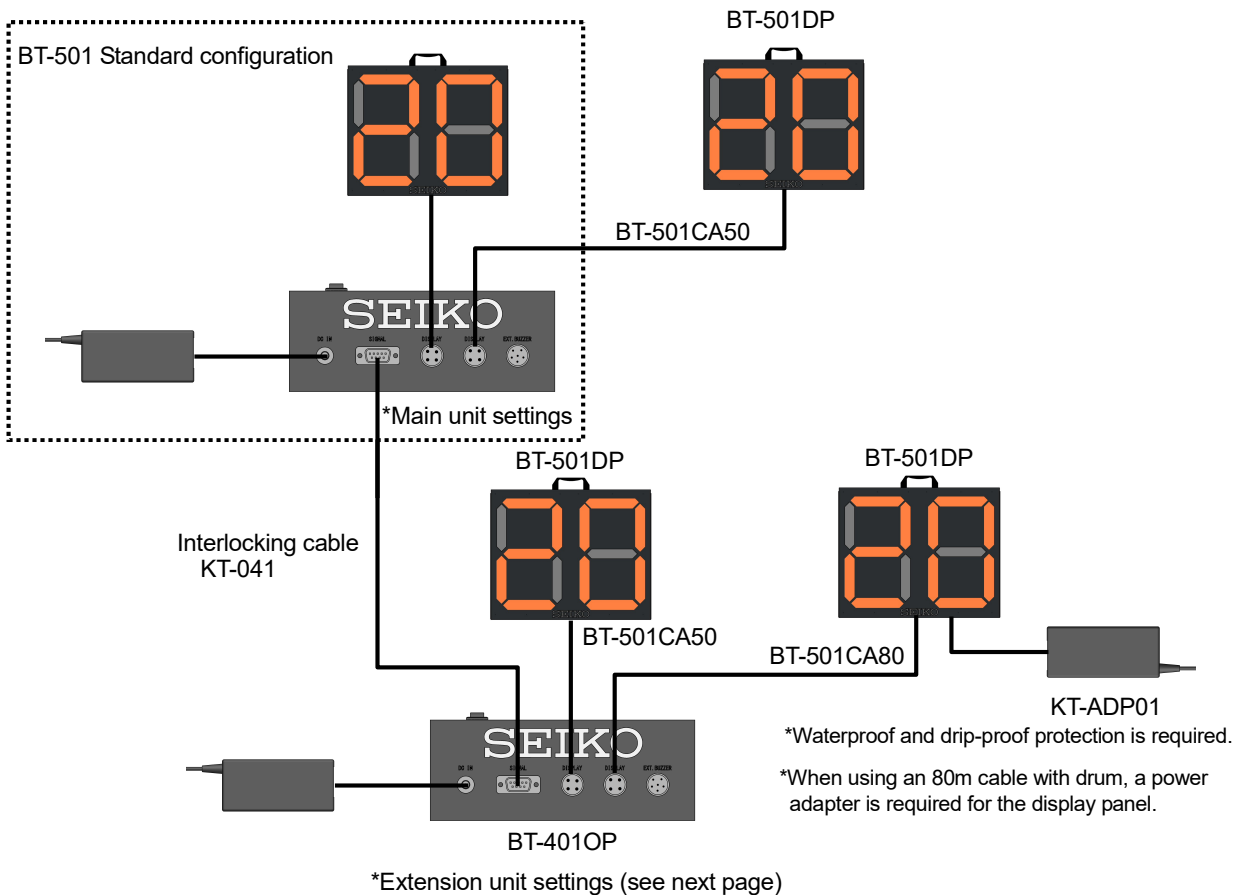

3. When expanding the array by connecting display panels together

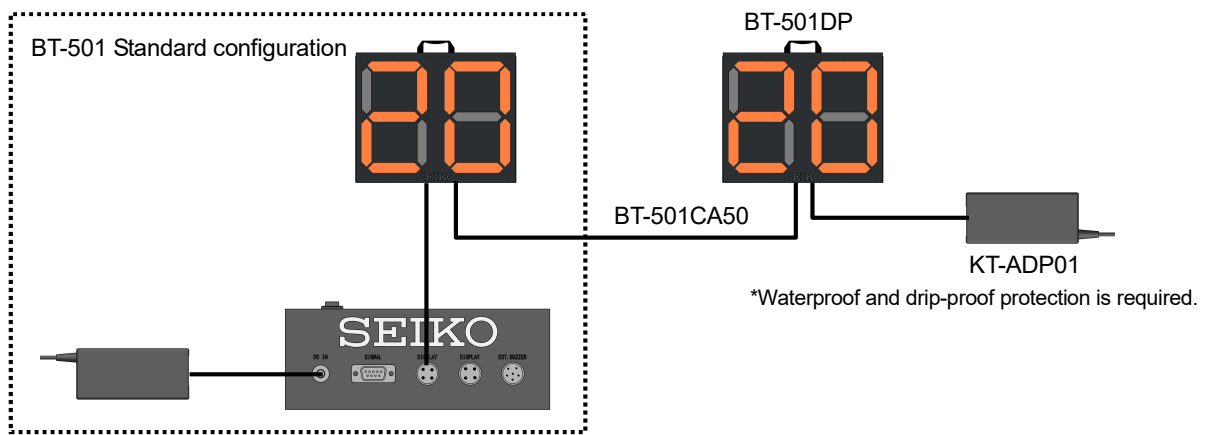















8. Operating Modes of the Control Panel

The control panel has a normal mode and a cycle mode, and the following three modes selections can be made depending on the startup method.

(While pressing each button, turn on the power and wait 3 seconds before releasing the button.)

- Normal mode: Mode used for a normal pitch clock
 - Usually set from the main unit. When linking two units to expand the array, set one unit as the extension unit.
- Cycle mode: Mode used for practice (see next page)

	Mode	Operation	Display at startup
1-1	Normal mode (Main unit operation)	 + Power ON START/STOP	 Flashes 3 times →Lights up  Light off  Light on  Number of seconds
1-2	Normal mode (Extension unit operation)	 + Power ON NO	 Flashes 3 times →Lights up  Light off  Light off  Linked to the main unit
2	Cycle mode	 + Power ON	 Flashes 3 times →Lights up  Light off  Light off  C for "cycle"

*If you start up in normal mode (either from the main unit or the extension unit), the method of use will be memorized, so that the next time you use it you can start it up the same way just by turning on the power.

*If there is no input from the main unit when starting up from the extension unit, the display monitor will turn off.

*Control operations cannot be performed from the extension unit, only from the main unit. (The display monitor on the extension unit is linked to the display on the main unit.)

9. Cycle Mode

By setting the control panel to cycle mode, the count will automatically repeat at the specified number of seconds.

This mode can be used for training, etc.

●Activation of cycle mode



Press and hold [TIME A/B] while turning on the power. → Cycle mode

* Continue pressing until  appears on the display monitor (about 3 seconds).



Flashes 3 times
→Lights up

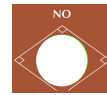

Light off

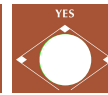







Light off

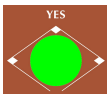

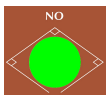

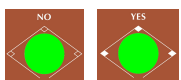
Display monitor





●Button selection

	Operation details	Operation	Action	Display monitor
●For a 20-second cycle				
1	Press the YES button.		*START/STOP button lights up red *YES button lights up green	
●For a 12-second cycle				
2	Press the NO button.		*START/STOP button lights up red *NO button lights up green	
●For an alternating 20-second/12-second cycle				
3	Press the YES and NO buttons simultaneously.		*START/STOP button lights up red *YES, NO buttons light up green	

●Operation Method

	Operation details	Operation	Action	Action (display monitor)
4-1	Start cycle operation		*START/STOP button flashes red	YES button (20-second) cycle 20 >19 >>>> 2 >1 > <u>20</u> >19 >>>> 2 >1 > <u>20</u> >19 >>>> NO button (12-second) cycle 12 >11 >>>> 2 >1 > <u>12</u> >11 >>>> 2 >1 > <u>12</u> >11 >>>> YES/NO button (20-second/12-second) alternating cycle 20 >19 >>>> 2 >1 > <u>12</u> >11 >>>> 2 >1 > <u>20</u> >19 >>>> *When the buzzer is ON, the buzzer will sound at the underlined seconds.
4-2	End cycle operation		*START/STOP button lights up red *YES, NO button lights go off	 Returns to immediately after start of cycle mode.

●Notes regarding cycle mode

- Once a cycle operation has started, it cannot be paused or restarted in the middle of operation.
- The number of seconds for the YES/NO button is the same as that for normal mode TIME A.
The number of seconds cannot be changed in cycle mode.
*If you change and save the TIME A YES button to 24 seconds, the cycle mode will become a 24-second cycle.
Refer to “●Changing measurement time settings” on page 7.
- Even in cycle mode, the brightness can be changed if done before start.
(The procedure for making the change is the same as in normal mode.)
Note that the same brightness value is shared between normal mode and cycle mode.
- The   and  buttons can each be operated at any time during cycle mode.
- The  button cannot be used.

●Using the display panel without connecting the control panel

- If you connect the power adapter directly to the display panel without connecting the control panel, the display panel will operate in a fixed 20-second cycle mode.

10. If a Communication Error Occurs

If the signal (display data) from the control panel cannot be received during operation, [— —] will appear on the display panel.



When a communication error occurs

When the signal returns to normal, the display will also return to normal.

For inquiries and repair requests regarding this product, please contact us via the website below.

<https://www.seiko-stc.co.jp>



セイコータイムクリエーション株式会社
SEIKO TIME CREATION INC.